

# ISO Mini Cylinder

Double Acting, Single Rod / Double rod; Single Acting, Spring Return / Extend

## Series C85

### ◆ How to Order

**C D 85 W N 20 40 S C B**

#### Auto switch mounting style

<b>A</b>	Rail mounting	<b>B</b>	Band mounting
----------	---------------	----------	---------------

#### Cushion

<b>Nil</b>	Rubber bumper(standard)
<b>C</b>	Adjustable air cushion at both ends (only "N" execution,bores 10 to 25mm)

#### Action

<b>Nil</b>	Double acting, single / double rod	
<b>S</b>	Single acting, spring return	<b>T</b> Single acting, spring extend

#### Cylinder stroke (mm)

Refer to "Standard Stroke".

#### Bore size (mm)

<b>8*</b>	<b>10</b>	<b>12</b>	<b>16</b>	<b>20</b>	<b>25</b>
-----------	-----------	-----------	-----------	-----------	-----------

\* Bore size 8mm not available with air cushion.

#### Head cover style

<b>N</b>	Basic integrated devis
<b>E*</b>	Double end
<b>F</b>	Boss cut
<b>Y**</b>	Boss cut-End port

\*Double acting, Double rod: Only double end style (E).

\*\*Except air cushion type.Except single acting spring extended type.

#### Piston Rod

<b>Nil</b>	Single rod	<b>W</b>	Double rod
------------	------------	----------	------------

#### Magnet

<b>Nil</b>	Without magnet	<b>D</b>	Built-in magnet
------------	----------------	----------	-----------------

### ◆ Specifications

Bore size (mm)		8	10	12	16	20	25
Action	C(D)85(W)N□-□	Double acting, single rod / double rod					
	C(D)85N□-□-S/T	Single acting, spring return / extend					
Fluid		Filtered compressed air					
Proof pressure		1.5MPa					
Operating pressure range	C(D)85(W)N□-□	0.1~1.0MPa	0.08~1.0MPa		0.05~1.0MPa		
	C(D)85N□-□-S/T	0.22~1.0MPa	0.18~1.0MPa		0.13~1.0MPa		
Ambient and fluid temperature		-20 to 80 °C (No freezing)					
Piston rod thread		M4×0.7		M6×1.0		M8×1.25	M10×1.25
Port size		M5×0.8				G1/8	
Cushion	C(D)85(W)N□-□	Rubber bumper					
	C(D)85N□-□-S/T	-	Adjustable air cushion at both ends				
	C(D)85N□-□-S/T	Rubber bumper					

Note): Please contact with ANSSION for the mounting accessories.

# ISO Mini Cylinder

Double Acting, Single Rod / Double rod; Single Acting, Spring Return / Extend

## Series C85



### Cylinder stroke

Bore size (mm)	standard stroke (mm)*	Max.stroke (mm)
8	10,25,40,50,80,100	400
10		
12		
16		
20	10,25,40,50,80,100,	1000
25		

\* Other strokes available on request.



### Symbol

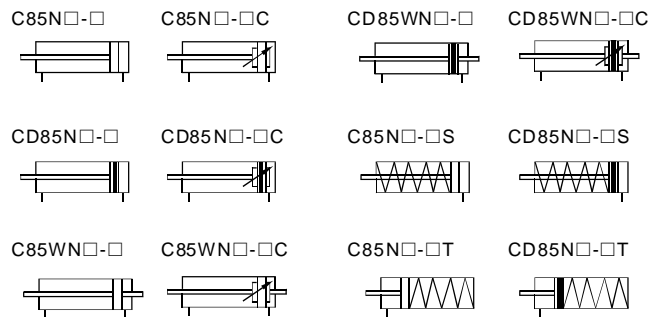

### ◆ Dimensions

#### C(D)85N□-□

(Basic style, rubber bumper)

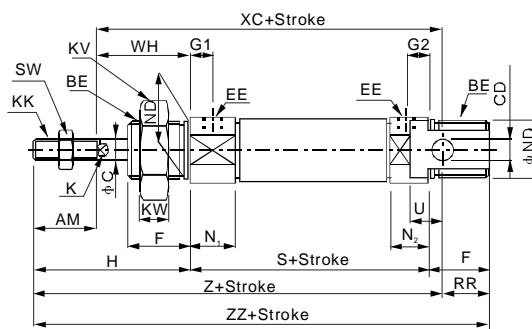
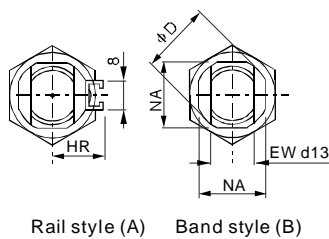

Note): The dimensions of built-in magnet type cylinder are exactly the same as without-magnet type cylinder.

#### C(D)85N□-□C

(Basic style, air cushion)

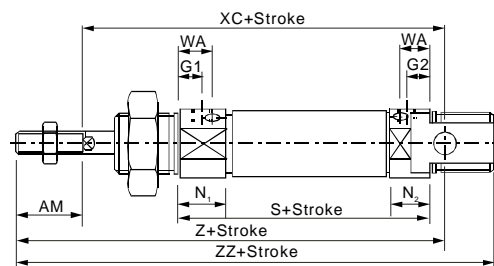
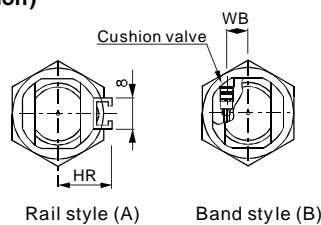

Note): The dimensions of built-in magnet type cylinder are exactly the same as without-magnet type cylinder.

Bore size (mm)	AM	BE	φC	CD	φD	EE	EW	F	G1	G2	WA	WB	H	HR	K	KA	KK	KV	KW	N1	N2	NA	φND(h8)	RR	S	SW	U	WH	XC	Z	ZZ
8	12	M12×1.25	4	4 <sup>+0.030</sup> <sub>0</sub>	16.7	M5×0.8	8	12	7	5	-	-	28	10	-	4.2	M4×0.7	19	6	11.5	9.5	15	12	10	46	7	6	16	64	76	86
10	12	M12×1.25	4	4 <sup>+0.030</sup> <sub>0</sub>	16.7	M5×0.8	8	12	7 <sup>(5.5)</sup>	5 <sup>(6.5)</sup>	10.5	4.5	28	10.5	-	4.2	M4×0.7	19	6	11.5 <sup>(13.5)</sup>	9.5 <sup>(13.5)</sup>	15	12	10	46 <sup>(53)</sup>	7	6	16	64 <sup>(71)</sup>	76 <sup>(83)</sup>	86 <sup>(93)</sup>
12	16	M16×1.5	6	6 <sup>+0.030</sup> <sub>0</sub>	19.7	M5×0.8	12	17	8 <sup>(5.5)</sup>	6 <sup>(6.5)</sup>	9.5	5.5	38	14	5	6.2	M6×1.0	24	8	12.5 <sup>(12.5)</sup>	10.5 <sup>(12.5)</sup>	18	16	14	50 <sup>(64)</sup>	10	9	22	75 <sup>(79)</sup>	91 <sup>(95)</sup>	105 <sup>(109)</sup>
16	16	M16×1.5	6	6 <sup>+0.030</sup> <sub>0</sub>	19.7	M5×0.8	12	17	8 <sup>(5.5)</sup>	6 <sup>(6.5)</sup>	9.5	5.5	38	14	5	6.2	M6×1.0	24	8	12.5 <sup>(12.5)</sup>	10.5 <sup>(12.5)</sup>	18	16	13	50 <sup>(66)</sup>	10	9	22	82 <sup>(82)</sup>	98 <sup>(98)</sup>	111 <sup>(111)</sup>
20	20	M22×1.5	8	8 <sup>+0.036</sup> <sub>0.006</sub>	28	G1/8	16	20	8	8	13	8.5	44	17	6	8.2	M8×1.25	32	10	15 <sup>(17)</sup>	15 <sup>(17)</sup>	24	22	11	62	13	12	24	95	115	126
25	22	M22×1.5	10	8 <sup>+0.036</sup> <sub>0.006</sub>	33.5	G1/8	16	22	8	8	13	10.5	50	20	8	10.2	M10×1.25	32	10	15 <sup>(17)</sup>	15 <sup>(17)</sup>	30	22	11	65	17	12	28	104	126	137

(): In case of air cushion.

I

CJP

CJ1

DNC

DNCB

DNG

C95

SI

CS1

MB

SU

SC

DSNU

**C85**

CJ2

CM2

MA

MAL

ADVU

CQ2

CQS

SDA

CU

DPZ

CXS

TN

ADVUL

CQM

MGP

MGG

CRA1

CY1B

CS  
Auto switch

D  
Auto switch

AC,AD

HR

RB

RBQ

# ISO Mini Cylinder

Double Acting, Single Rod / Double rod; Single Acting, Spring Return / Extend

## Series C85

### C(D)85E□-□

(Double end style, rubber bumper)

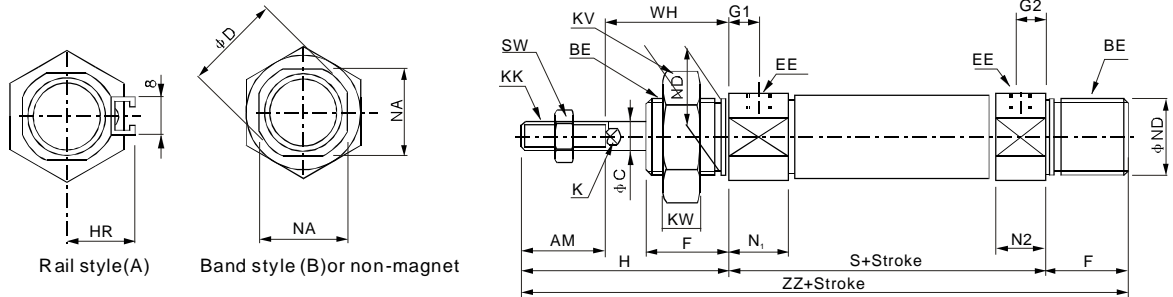

Note): The dimensions of built-in magnet type cylinder are exactly the same as without-magnet type cylinder.

Bore size (mm)	AM	BE	φC	φD	EE	F	G1	G2	H	HR	K	KA	KK	KV	KW	N1	N2	NA	φND(h8)	S	SW	WH	ZZ
8	12	M12×1.25	4	16.7	M5×0.8	12	7	-	28	10	-	4.2	M4×0.7	19	6	11.5	9.5	15	12	46	7	16	86
10	12	M12×1.25	4	16.7	M5×0.8	12	7	10.5	28	10.5	-	4.2	M4×0.7	19	6	11.5	9.5	15	12	46	7	16	86
12	16	M16×1.5	6	19.7	M5×0.8	17	8	9.5	38	14	5	6.2	M6×1.0	24	8	12.5	10.5	18	16	50	10	22	105
16	16	M16×1.5	6	19.7	M5×0.8	17	8	9.5	38	14	5	6.2	M6×1.0	24	8	12.5	10.5	18	16	56	10	22	111
20	20	M22×1.5	8	28	G1/8	20	8	13	44	17	6	8.2	M8×1.25	32	10	15	15	24	22	62	13	24	126
25	22	M22×1.5	10	33.5	G1/8	22	8	13	50	20	8	10.2	M10×1.25	32	10	15	15	30	22	65	17	28	137

### C(D)85<sub>Y</sub>□-□

(Boss cut "F" / boss cut-end port "Y" style, rubber bumper)

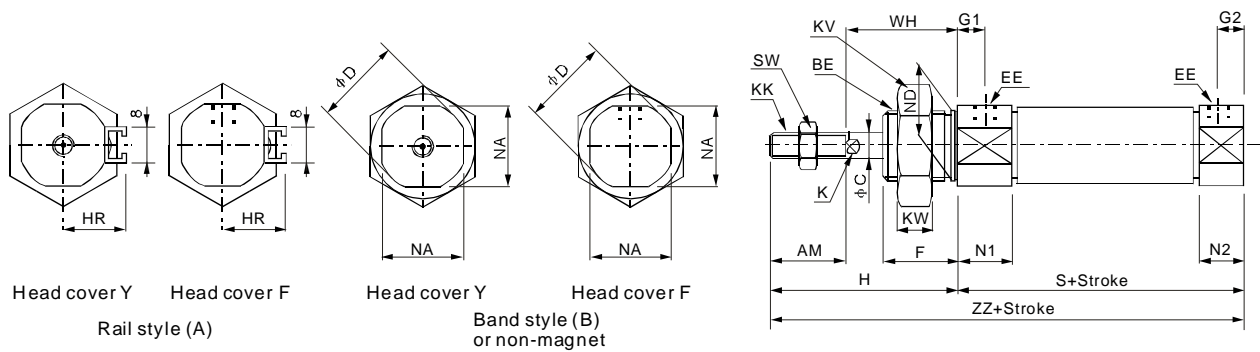

Note): The dimensions of built-in magnet type cylinder are exactly the same as without-magnet type cylinder.

Bore size (mm)	AM	BE	φC	φD	EE	F	G1	G2	H	HR	HR	K	KK	KV	KW	N1	N2	NA	φND(h8)	S	SW	WH	ZZ
8	12	M12×1.25	4	16.7	M5×0.8	12	7	5	28	10	10	-	M4×0.7	19	6	11.5	9.5	15	12	46	7	16	74
10	12	M12×1.25	4	16.7	M5×0.8	12	7	5	28	10.5	10.5	-	M4×0.7	19	6	11.5	9.5	15	12	46	7	16	74
12	16	M16×1.5	6	19.7	M5×0.8	17	8	6	38	14	14	5	M6×1.0	24	8	12.5	10.5	18	16	50	10	22	88
16	16	M16×1.5	6	19.7	M5×0.8	17	8	6	38	14	14	5	M6×1.0	24	8	12.5	10.5	18	16	50	10	22	88
20	20	M22×1.5	8	27.9	G1/8	20	8	8	44	17	17	6	M8×1.25	32	11	15	15	24	22	62	13	24	106
25	22	M22×1.5	10	33.4	G1/8	22	8	8	50	20	20	8	M10×1.25	32	11	15	15	30	22	65	17	28	115

# ISO Mini Cylinder

Double Acting, Single Rod / Double rod; Single Acting, Spring Return / Extend

## Series C85



### C(D)85WE□-□ (Double rod style)

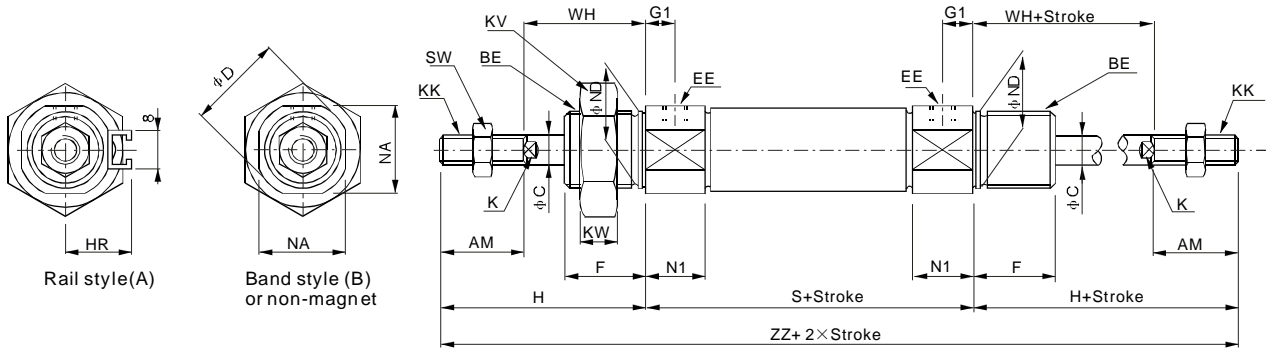

Note: The dimensions of built-in magnet type cylinder are exactly the same as without-magnet type cylinder, except the { }.

### C(D)85WE□-□C (Double rod style, air cushion)

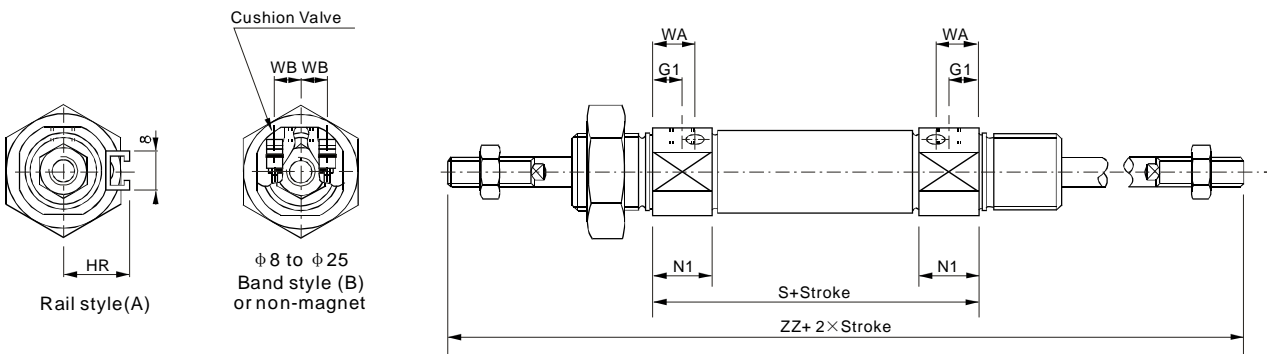

Note: The dimensions of built-in magnet type cylinder are exactly the same as without-magnet type cylinder, except the { }.

Bore	AM	BE	φC	φD	EE	F	G1	WA	WB	H	HR	K	KK	KV	KW	N1	NA	φND(h8)	S	SW	WH	ZZ
8	12	M12×1.25	4	16.7	M5×0.8	12	7	-	-	28	10	-	M4×0.7	19	6	11.5	15	12	48{54}	7	16	104{110}
10	12	M12×1.25	4	16.7	M5×0.8	12	7(5.5)	10.5	4.5	28	10.5	-	M4×0.7	19	6	11.5(13.5)	15	12	48{53}	7	16	104{109}
12	16	M16×1.5	6	19.7	M5×0.8	17	8(5.5)	9.5	5.5	38	14	5	M6×1.0	24	8	12.5(12.5)	18	16	52{54}	10	22	128{130}
16	16	M16×1.5	6	19.7	M5×0.8	17	8(5.5)	9.5	5.5	38	14	5	M6×1.0	24	8	12.5(12.5)	18	16	52{54}	10	22	128{143}
20	20	M22×1.5	8	28	G1/8	20	8	13	8.5	44	17	6	M8×1.25	32	11	15(17)	24	22	62	13	24	150
25	20	M22×1.5	10	33.5	G1/8	22	8	13	10.5	50	20	8	M10×1.25	32	11	15(17)	30	22	65	17	28	165

( ):In case of air cushion. { }:In case of built in magnet

### C(D)85<sup>N</sup><sub>E</sub>□-□S (Spring return style)

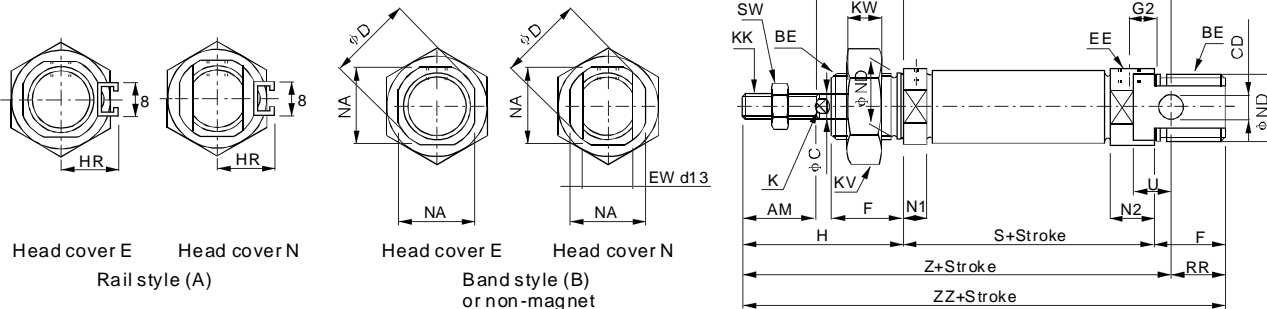

Note: The dimensions of built-in magnet type cylinder are exactly the same as without-magnet type cylinder, except the ( ).

I

CJP

CJ1

DNC

DNCB

DNG

C95

SI

CS1

MB

SU

SC

DSNU

C85

CJ2

CM2

MA

MAL

ADVU

CQ2

CQS

SDA

CU

DPZ

CXS

TN

ADVUL

CQM

MGP

MGG

CRA1

CY1B

CS

Auto switch

D

Auto switch

AC,AD

HR

RB

RBQ

# ISO Mini Cylinder

Double Acting, Single Rod / Double rod; Single Acting, Spring Return / Extend

## Series C85

Bore	AM	BE	φC	CD	φD	EE	EW	F	G2	H	HR	K	KK	KV	KW	N1	N2	NA	φND(h8)	RR	SW	U	WH
φ 8	12	M12×1.25	4	4 <sup>+0.030</sup> <sub>0</sub>	16.7	M5×0.8	8	12	5	28	10	-	M4×0.7	19	6	5.5	9.5	15	12	10	7	6	16
φ 10	12	M12×1.25	4	4 <sup>+0.030</sup> <sub>0</sub>	16.7	M5×0.8	8	12	5	28	10.5	-	M4×0.7	19	6	5.5	9.5	15	12	10	7	6	16
φ 12	16	M16×1.5	6	6 <sup>+0.030</sup> <sub>0</sub>	19.7	M5×0.8	12	17	6	38	14	5	M6×1.0	24	8	5.5	10.5	18	16	14	10	9	22
φ 16	16	M16×1.5	6	6 <sup>+0.030</sup> <sub>0</sub>	19.7	M5×0.8	12	17	6	38	14	5	M6×1.0	24	8	5.5	10.5	18	16	13	10	9	22
φ 20	20	M22×1.5	8	8 <sup>+0.036</sup> <sub>0</sub>	27.9	G1/8	16	20	8	44	17	6	M8×1.25	32	11	15	15	24	22	11	13	12	24
φ 25	20	M22×1.5	10	8 <sup>+0.036</sup> <sub>0</sub>	33.4	G1/8	16	22	8	50	20	8	M10×1.25	32	11	15	15	30	22	11	17	12	28

Bore	S			XC			Z			ZZ		
	1 to 50	51 to 100	101 to 150	1 to 50	51 to 100	101 to 150	1 to 50	51 to 100	101 to 150	1 to 50	51 to 100	1 to 50
φ 8	46(52)	-	-	64(70)	-	-	76(82)	-	-	86(92)	-	-
φ 10	46(50)	-	-	64(68)	-	-	76(80)	-	-	86(90)	-	-
φ 12	50(53.5)	-	-	7.5(78.5)	-	-	91(94.5)	-	-	105(108.5)	-	-
φ 16	56(59.5)	71.5(75)	87(90.5)	82(85.5)	97.5(101)	113(116.5)	98(101.5)	113.5(117)	129(132.5)	111(114.5)	126.5(130)	142(145.5)
φ 20	62	112	137	95	145	170	115	165	190	126	176	201
φ 25	65	113.5	138.5	104	152.5	177.5	126	174.5	199.5	137	185.5	210.5

( ): In case of built-in magnet

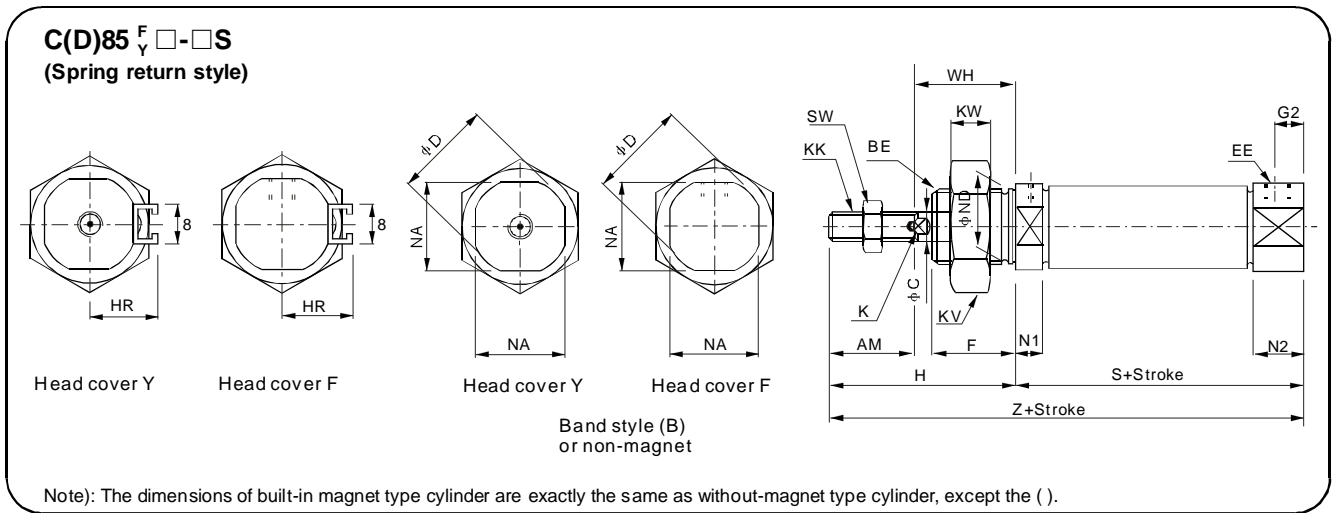

Bore	AM	BE	φC	φD	EE	F	G2	H	HR	K	KK	KV	KW	N1	N2	NA	φND(h8)	SW	WH
φ 8	12	M12×1.25	4	16.7	M5×0.8	12	5	28	10	-	M4×0.7	19	6	5.5	9.5	15	15	7	16
φ 10	12	M12×1.25	4	16.7	M5×0.8	12	5	28	10.5	-	M4×0.7	19	6	5.5	9.5	15	15	7	16
φ 12	16	M16×1.5	6	19.7	M5×0.8	17	6	38	14	5	M6×1.0	24	8	5.5	10.5	18	18	10	22
φ 16	16	M16×1.5	6	19.7	M5×0.8	17	6	38	14	5	M6×1.0	24	8	5.5	10.5	18	18	10	22
φ 20	20	M22×1.5	8	27.9	G1/8	20	8	44	17	6	M8×1.25	32	10	15	15	24	24	13	24
φ 25	20	M22×1.5	10	33.4	G1/8	22	8	50	20	8	M10×1.25	32	10	15	15	30	30	17	28

Bore	S			XC			Z			ZZ		
	1 to 50	51 to 100	101 to 150	1 to 50	51 to 100	101 to 150	1 to 50	51 to 100	101 to 150	1 to 50	51 to 100	1 to 50
φ 8	46(52)	-	-	74(80)	-	-	74(80)	-	-	-	-	-
φ 10	46(50)	-	-	74(78)	-	-	74(78)	-	-	-	-	-
φ 12	50(53.5)	-	-	88(91.5)	-	-	88(91.5)	-	-	-	-	-
φ 16	50(53.5)	65.5(69)	81(84.5)	88(91.5)	103.5(107)	119(122.5)	88(91.5)	103.5(107)	119(122.5)	119(122.5)	135(138.5)	151(154.5)
φ 20	62	112	137	106	156	181	106	156	181	126	176	201
φ 25	65	113.5	138.5	115	163.5	188.5	115	163.5	188.5	137	185.5	210.5

( ): In case of built-in magnet

# ISO Mini Cylinder

Double Acting, Single Rod / Double rod; Single Acting, Spring Return / Extend

## Series C85



**C(D)85<sup>N</sup> □-□T**  
(Spring extend style)

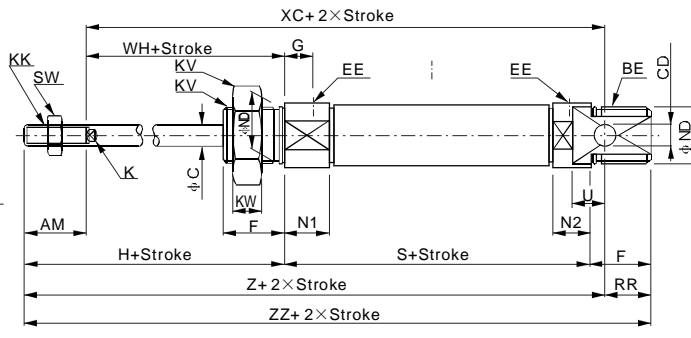
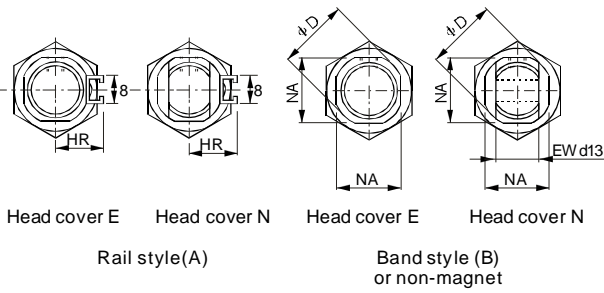

Note): The dimensions of built-in magnet type cylinder are exactly the same as without-magnet type cylinder, except the ( ).

Unit:(mm)

Bore	AM	BE	φC	CD	φD	EE	EW	F	G	H	HR	K	KK	KV	KW	N <sub>1</sub>	N <sub>2</sub>	NA	φND(h8)	RR	SW	U	WH
φ 8	12	M12×1.25	4	4 <sup>+0.030</sup> <sub>0</sub>	16.7	M5×0.8	8	12	7	28	10	—	M4×0.7	19	6	11.5	9.5	15	12	10	7	6	16
φ 10	12	M12×1.25	4	4 <sup>+0.030</sup> <sub>0</sub>	16.7	M5×0.8	8	12	7	28	10.5	—	M4×0.7	19	6	11.5	9.5	15	12	10	7	6	16
φ 12	16	M16×1.5	6	6 <sup>+0.030</sup> <sub>0</sub>	19.7	M5×0.8	12	17	8	38	14	5	M6×1.0	24	8	12.5	10.5	18.3	16	14	10	9	22
φ 16	16	M16×1.5	6	6 <sup>+0.030</sup> <sub>0</sub>	19.7	M5×0.8	12	17	8	38	14	5	M6×1.0	24	8	12.5	10.5	18.3	16	13	10	9	22
φ 20	20	M22×1.5	8	8 <sup>+0.036</sup> <sub>-0.006</sub>	27.9	G1/8	16	20	8	44	17	6	M8×1.25	32	11	15	15	24	22	11	13	12	24
φ 25	22	M22×1.5	10	8 <sup>+0.036</sup> <sub>-0.006</sub>	33.4	G1/8	16	22	8	50	20	8	M10×1.25	32	11	15	15	30	22	11	17	12	28

Bore	S			Z			XC			ZZ		
	1 to 50	51 to 100	101 to 150	1 to 50	51 to 100	101 to 150	1 to 50	51 to 100	101 to 150	1 to 50	51 to 100	101 to 150
φ 8	64.5(70.5)	—	—	94.5(100.5)	—	—	82.5(88.5)	—	—	104.5(110.5)	—	—
φ 10	64.5(68.5)	—	—	94.5(98.5)	—	—	82.5(86.5)	—	—	104.5(108.5)	—	—
φ 12	70(73.5)	—	—	111(114.5)	—	—	95(98.5)	—	—	125(128.5)	—	—
φ 16	75(78.5)	101(104.5)	127(130.5)	117(120.5)	143(146.5)	169(172.5)	101(104.5)	127(130.5)	153(156.5)	130(133.5)	156(159.5)	182(185.5)
φ 20	87	112	137	140	165	190	120	145	170	151	176	201
φ 25	88.5	113.5	138.5	149.5	174.5	199.5	127.5	152.5	177.5	160.5	185.5	210.5

( ): In case of built-in magnet

- I
- CJP
- CJ1
- DNC
- DNCB
- DNG
- C95
- SI
- CS1
- MB
- SU
- SC
- DSNU
- C85**
- CJ2
- CM2
- MA
- MAL
- ADVU
- CQ2
- CQS
- SDA
- CU
- DPZ
- CXS
- TN
- ADVUL
- CQM
- MGP
- MGG
- CRA1
- CY1B
- CS  
Auto switch
- D  
Auto switch
- AC,AD
- HR
- RB
- RBQ

# ISO Mini Cylinder

Double Acting, Single Rod / Double rod; Single Acting, Spring Return / Extend

## Series C85

**C(D)85F□-□T**  
(Spring extend style)

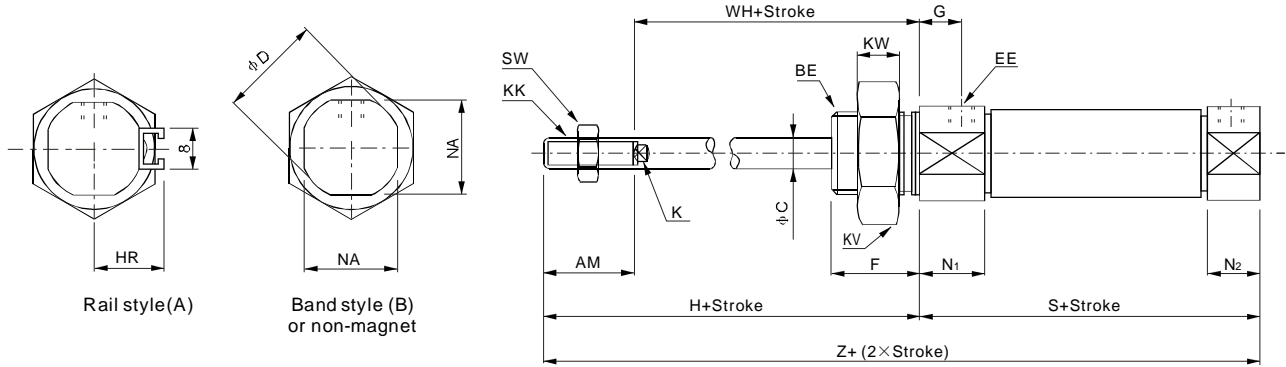

Note: The dimensions of built-in magnet type cylinder are exactly the same as without-magnet type cylinder, except the ( ).

Unit:(mm)

Bore size	AM	BE	φC	φD	EE	F	G	H	HR	K	KK	KV	KW	N <sub>1</sub>	N <sub>2</sub>	NA	SW	WH
φ 8	12	M12×1.25	4	16.7	M5×0.8	12	7	28	10	—	M4×0.7	19	6	11.5	9.5	15	7	16
φ 10	12	M12×1.25	4	16.7	M5×0.8	12	7	28	10.5	—	M4×0.7	19	6	11.5	9.5	15	7	16
φ 12	16	M16×1.5	6	19.7	M5×0.8	17	8	38	14	5	M6×1.0	24	8	12.5	10.5	18.3	10	22
φ 16	16	M16×1.5	6	19.7	M5×0.8	17	8	38	14	5	M6×1.0	24	8	12.5	10.5	18.3	10	22
φ 20	20	M22×1.5	8	27.9	G1/8	20	8	44	17	6	M8×1.25	32	11	15	15	24	13	24
φ 25	22	M22×1.5	10	33.4	G1/8	22	8	50	20	8	M10×1.25	32	11	15	15	30	17	28

Bore	S			Z		
	1 to 50	51 to 100	101 to 150	1 to 50	51 to 100	101 to 150
φ 8	64.5(70.5)	—	—	92.5(98.5)	—	—
φ 10	64.5(68.5)	—	—	92.5(96.5)	—	—
φ 12	70(73.5)	—	—	108(111.5)	—	—
φ 16	69(72.5)	95(98.5)	121(124.5)	107(110.5)	133(136.5)	159(162.5)
φ 20	87	112	137	131	156	181
φ 25	88.5	113.5	138.5	138.5	163.5	188.5

( ): In case of built-in magnet