

Guide Cylinder

Double Acting, Single Rod, Basic Type

Series MGG

◆ How to Order

MGG **M** **B** **32** - **100**

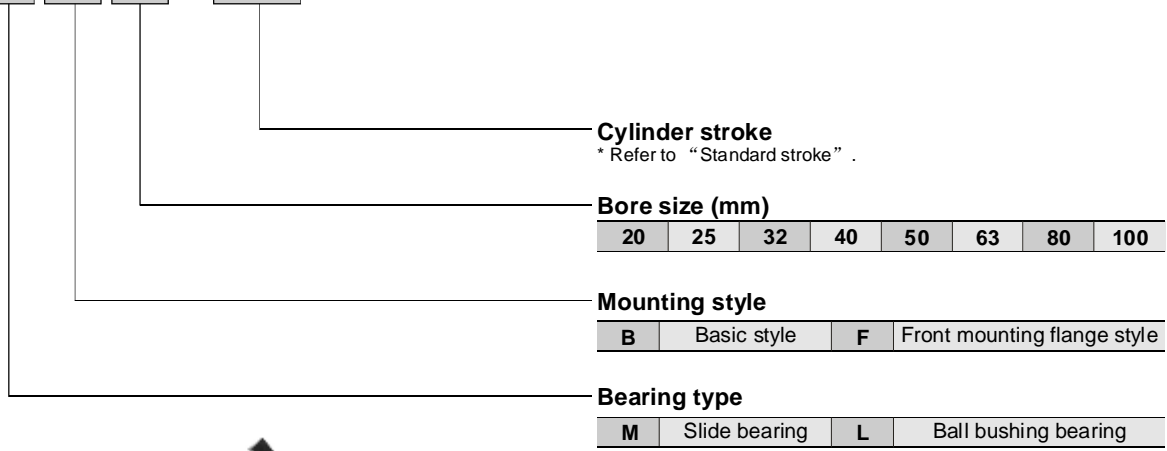

Symbol

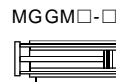

◆ Specifications

Bore size (mm)	20	25	32	40	50	63	80	100
Action	Double acting							
Fluid	Filtered compressed air							
Proof pressure	1.5 MPa							
Operating pressure range	0.15~1.0 MPa							
Ambient and fluid temperature	-10~60℃ (No freezing)							
Port size	Rc1/8			Rc1/4		Rc3/8	Rc1/2	
Cushion	Basic cylinder	Rubber bumper						
	Guide unit	Built-in shock absorbers (2 pcs.)						
Stroke adjusting range(One side) [Built-in adjusting bolts(2 pcs.)]	0--10mm	0--15mm						
Mounting style	Basic style, Front mounting flange style.							

◆ Standard Stroke

Model	Bearing type	Bore size(mm)	Standard stroke(mm)	Long stroke(mm)
MGGM	Slide bearing	20	75,100,125,150,200	250,300,350,400
		25	75,100,125,150,200, 250,300	350,400,450,500
		32		350,400,450,500,600
		40		350,400,450,500,600,700,800
MGGL	Ball bushing bearing	50		75,100,125,150,200, 250,300
		63	350,400,450,500,600,700,800,900,1000,1100	
		80	350,400,450,500,600,700,800,900,1000,1100,1200	
		100	350,400,450,500,600,700,800,900,1000,1100,1200,1300	

Guide Cylinder Double Acting, Single Rod, Basic Type Series MGG



◆ Shock Absorber Specifications

Shock absorber model		RB1007	RN1412	RB2015	RB2725
Applicable guide cylinder		MGG□□20	MGG□□25/32	MGG□□40/50/63	MGG□□80/100
Maximum energy absorption		5.88 J	19.6 J	58.8 J	147 J
Stroke absorption		7 mm	12 mm	15 mm	25 mm
Maximum collision speed		5 m/s			
Max. operating frequency *		70 cycle/min	45 cycle/min	25 cycle/min	10 cycle/min
Ambient temperature range		-10~80°C			
Spring force	Extended	4.22 N	6.86 N	8.34 N	8.83 N
	Retracted	6.860 N	15.98 N	20.5 N	20.01 N

* It denotes the values at the maximum energy absorption per one cycle. Therefore, the operating frequency can be increased according to the energy absorption.

◆ Dimensions

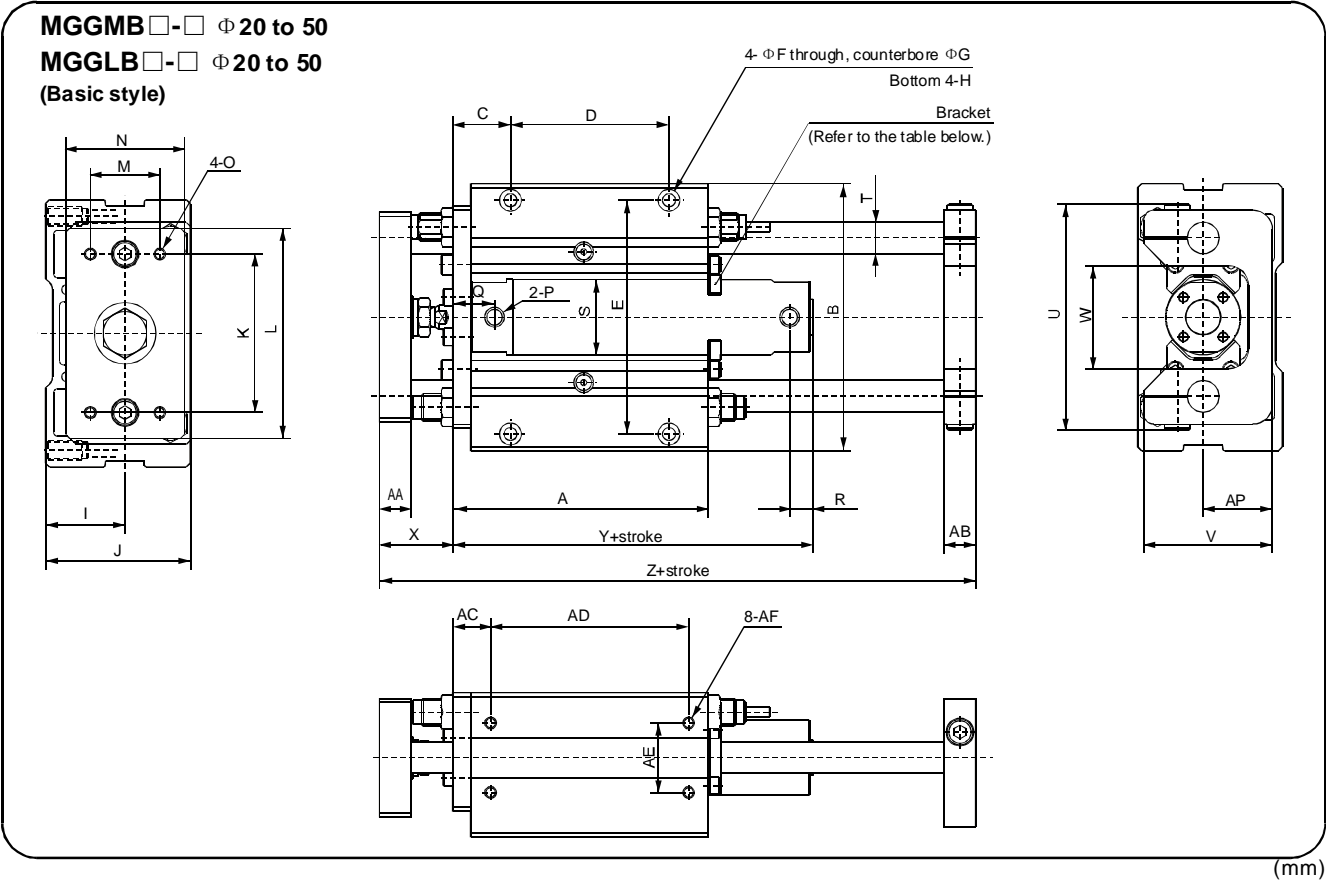

Bore size (mm)	Stroke range (mm)	Dimensions (mm)																																
		A	AA	AB	AC	AD	AE	AF	AP	B	C	D	E	F	G	H	I	J	K	L	M	N	O	P	Q	R	S	T	U	V	W	X	Y	Z
20	75,100,125,150,200	99	12	11	16.5	75	30	M5×0.8 depth 10	25	108	24	60	92	5.5	9.5 depth 6	M8×1.25 depth 14	30	55	60	80	25	45	M6×1 depth 9	Rc 1/8	21	12	26	12	82	48	40	30	80	157
25	75,100,125,150,200,300	109	16	13	16.5	85	30	M6×1 depth 12	30	130	26.5	65	113	6.6	11 depth 8	M10×1.5 depth 18	35	65	70	100	35	54	M6×1 depth 13	Rc 1/8	21	12	31	13	100	57	46	37	80	175
32		129	16	16	18	100	35	M6×1 depth 12	35	135	29	80	118	6.6	11 depth 8	M10×1.5 depth 18	45	80	80	106	35	60	M6×1 depth 13	Rc 1/8	21	12	38	16	114	65	52	37	82	201
40		152	19	19	22	120	40	M8×1.25 depth 16	45	170	32	100	150	9	14 depth 10	M12×1.75 depth 21	50	194	37	120	50	75	M10×1.5 depth 20	Rc 1/8	25	12	47	20	138	84	62	44	92	238
50		182	25	21	22	150	45	M10×1.5 depth 20	50	194	37	120	170	11	17 depth 12	M14×2 depth 25				90	90		M10×1.5 depth 21	Rc 1/4	26	14	58	25	164	94	75	45	104	285

Long Stroke

Bore size (mm)	Stroke range (mm)	R	Y
20	250 to 400	14	88
25	350 to 500	14	88
32	350 to 600	14	90
40	350 to 800	15	101
50	350 to 1000	16	116

Bracket Mounting Stroke

Bore size (mm)	Bracket mounting stroke
20	100 st or more
25	125 st or more
32	150 st or more
40	200 st or more
50	250 st or more

I

CJP

CJ1

DNC

DNCB

DNG

C95

SI

CS1

MB

SU

SC

DSNU

C85

CJ2

CM2

MA

MAL

ADVU

CQ2

CQS

SDA

CU

DPZ

CXS

TN

ADVUL

CQM

MGP

MGG

CRA1

CY1B

CS

D

Auto switch

AC,AD

HR

RB

RBQ

Guide Cylinder

Double Acting, Single Rod, Basic Type

Series MGG

MGGMB □-□ Φ 63 to 100
MGGLB □-□ Φ 63 to 100
 (Basic style)

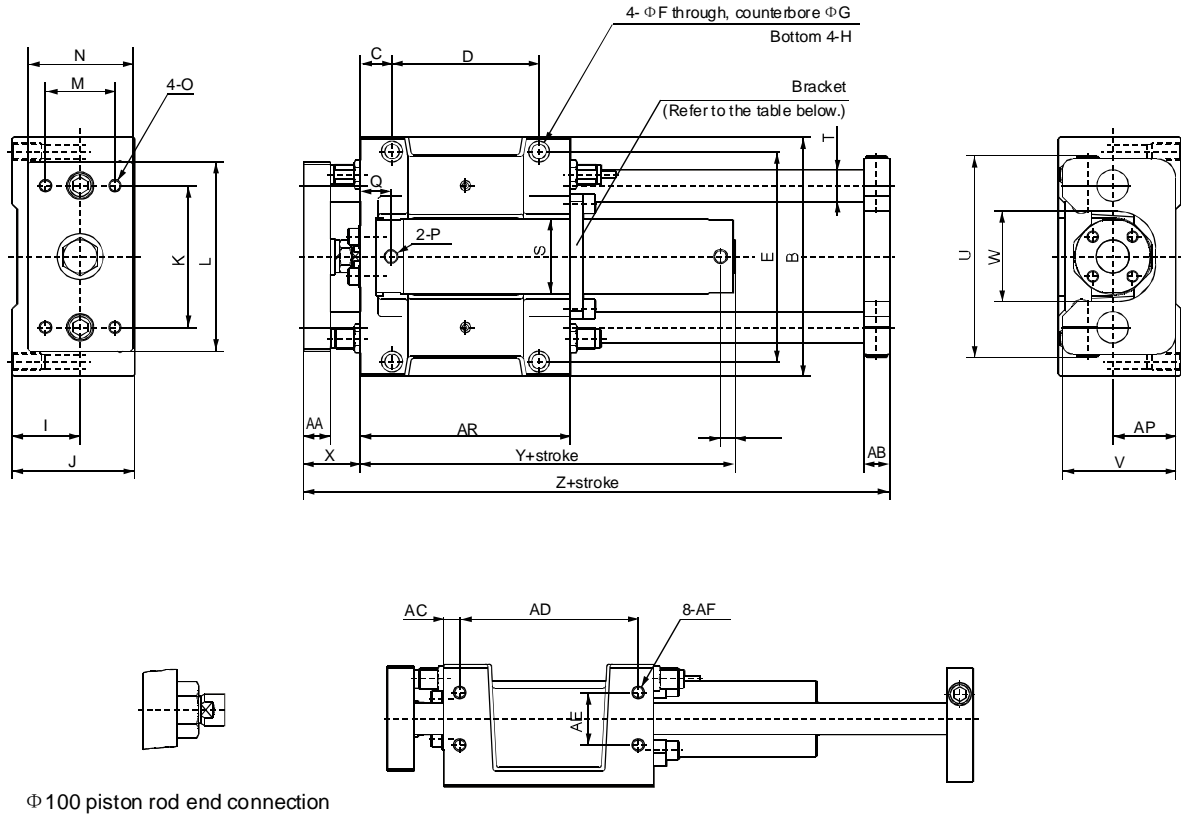

(mm)

Bore size (mm)	Stroke range (mm)	A	AA	AB	AC	AD	AE	AF	AP	B	C	D	E	F	G	H
63	75, 100,	200	25	25	15	170	50	M12×1.75 depth 24	60	228	30	140	200	13.5	20 depth 14.5	M16×2 depth 28
80	125, 150,	230	30	27	15	200	55	M12×1.75 depth 24	70	262	30	170	234	13.5	20 depth 14.5	M16×2 depth 28
100	200, 300	280	32	30	17.5	245	70	M14×2 depth 28	80	304	35	210	274	15	23 depth 17	M18×2.5 depth 32

Bore size (mm)	I	J	K	L	M	N	O	P	Q	R	S	T	U	V	W	X	Y	Z
63	65	117	135	180	66	100	M12×1.75 depth 23	Rc 1/4	29	14	72	30	192	108	86	54	107	308
80	75	138	160	214	76	115	M12×1.75 depth 28	Rc 3/8	40	19	89	35	224	128	104	66	131	355
100	85	153	190	245	80	125	M14×2 depth 30	Rc 1/2	40	19	110	40	262	143	128	66	131	410

Long Stroke

Bore size (mm)	Stroke range (mm)	R	Y
63	350 to 1100	16	119
80	350 to 1200	23	145
100	350 to 1300	23	145

Bracket Mounting Stroke

Bore size (mm)	Bracket mounting stroke
63	300 st or more
80	400 st or more
100	500 st or more